

LPG Tanker Semi Trailer - 3 Axle

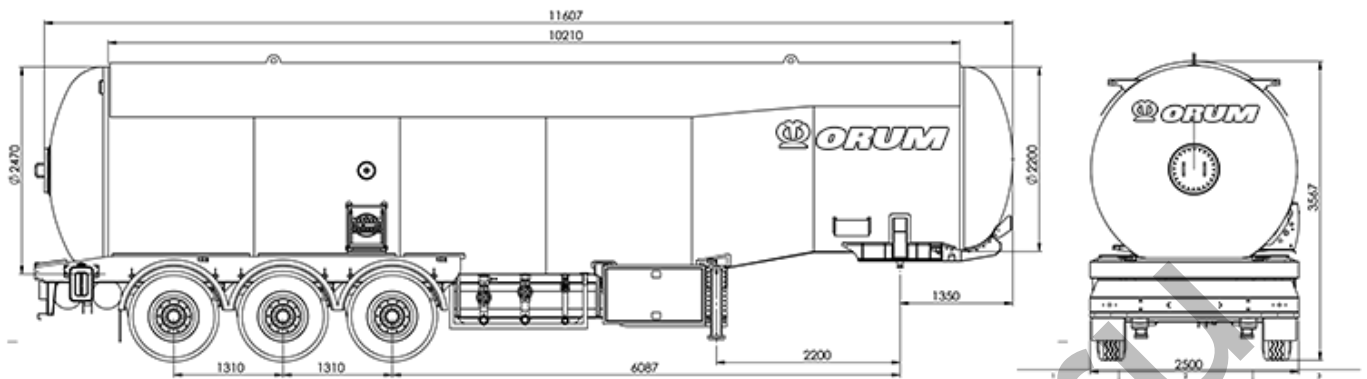

LPG Tanker Semi Trailer:



Tanker is used solely for the transport of liquids. Due to the type of fluid being shipped, the tank body can vary. While for the carriage of fuels (Gasoline, Diesel, Mazut, Kerosene) the body is made of carbon steel, for the transportation of hygienic fluids the body is mainly made of stainless steel. Using aluminum in certain cases, such as transporting of aircraft fuel is recommended for safety reasons but in other cases it may be used if cheap to run. Where liquids are corrosive (like acid or alkaline substances) the only economic solution is application of special coatings on the interior of the tank. Liquid in tanker is drained either by gravity (its own weight) or using a pump which is separately installed on the trailer and driven by a small diesel/gasoline engine.

Safety:

Transportation of liquids regardless of their type is dangerous from two aspects. First, when driving the movement of fluid in the tank causes strokes in the longitudinal and transversal direction, which can easily cause instability and result in accidents such as overturn or jackknife. Using baffles inside the tank is a decisive and appropriate solution to overcome such problems furthermore the existence of RSP (Roll Stability Program) in all MAMMUT products effectively fixes this problem. Another risk is the overflow and vapor control of liquids, which depending on the type of the liquid, there are some solutions such as: providing of overflow vent, vapor recovery path or transportation under positive pressure. Apparently compliance with ADR rules in construction of all tankers is a ORUM priority and privilege.

Accessories:

- Trailer park lock system
- Automatic front lift axle
- 60 Lit Water tank
- Holder for fire extinguisher
- Fix Rear bumper
- Toolbox
- Spare tire holder
- Valve box
- Plastic chock
- 6 pcs mud guards and 2 mud flaps
- Walkway covered with aluminum

- anti-slip plate

Options:

- Holding standard and certificate of welding inspection and dimensional control and hydrostatic test
- Optional rims and spare Tires
- Loading and unloading system control kit and emergency disconnection system

Technical Specifications:

- Chassis Construction: Chassis and other metal pieces are made of high-strength steel (S500MC) with special fixture automatic Co2 argon welding machine.
- Body Construction: Side walls, front and roof one-piece special insulated sandwich panel (polyurethane made in Germany) duplex Aluzinc prepainted sheet (sheet thickness exterior 0.8 mm and interior 0.5 mm, top coat 25-micron polyester paint and special primer undercoat); special aluminum track holder profiles (interior and exterior) / aluminum profiles with rivets.
- Walls: front wall: 100 mm reinforced for thermo king connection and thermo king shield * Roof: 100 mm reinforced for thermo king protector * Side wall: 60 mm * floor: 150 mm with foreign prepainted under flooring sheet and aluminum railings raised access floor for air flow from under pallets.
- Rear door: double barns with 2 hinges and 4 lockers, solid stainless steel and thickness of rear door 80 mm with P.V.C insulation and special Tires
- Braking System: EBS System (Electrical Anti Block Brake System) with RSP (Roll Stability Program) Disk and Drum, Knorr ® / Wabco ®(Germany) Two double acting diaphragm brake chamber per axle .
- Suspension and axles: 3x9 ton EU Standard disc brake or drum brake, front lift axle
- Painting: Shot blasted, according to SA2/5 and washed by special material, painted with a layer of epoxy primer and of polyurethane final coat
- Electric System: 7 and 15 Pole quick release connector, Austrian Pair of 24 volts rear light, side light and alarming system from Aspock with LED Type.
- Landing Legs: Static Capacity 50 Tons & Dynamic Capacity 24 Tons (SAF) Germany
- King pin: A flange type 2 Inch SAF king pin made in Germany
- Axle/ Suspension: axle with balloon air suspension system with special shock absorber Lower and Rise Capability of Trailer
- Tires: 6 pieces 385/65R22.5 (with manufacturer's guarantee)
- Rim: 6 single-piece rims 22.5 × 11.75

©<https://orumtrailer.ru>